



INSTALLATION INSTRUCTIONS/TORQUE SPECS FOR MF-3 MOUNT.

Make sure washers are in place. ¼ turn at a time in sequence shown below to 15 in-lbs dry.

Tools needed

Torque wrench

T15 torx bit-ring bolt

T25 torx bit-base bolt

No Loctite unless dried on bolts prior to installation.

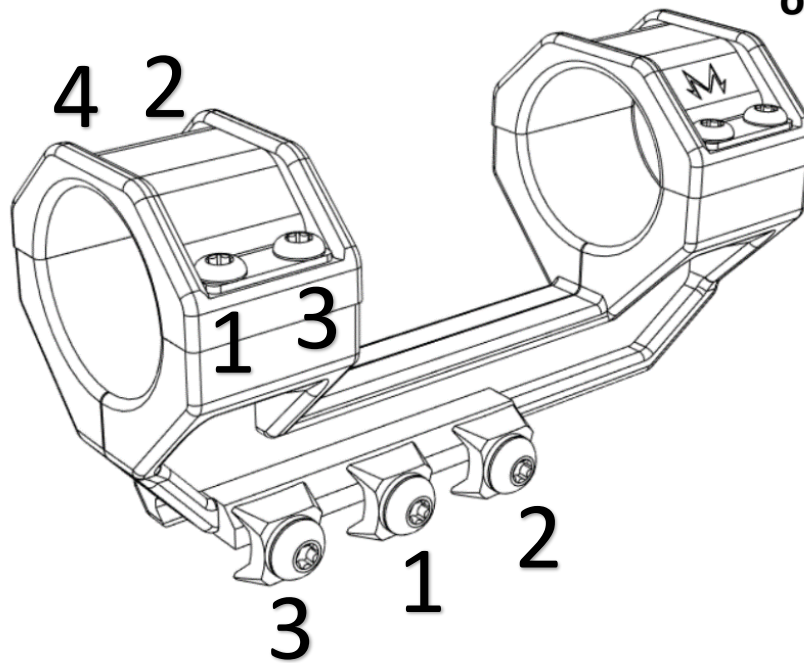

Make sure lugs are engaged to rail & washers are in place and torque to 25 in-lbs dry. ¼ turn at a time in sequence shown above.

FAILURE TO FOLLOW INSTRUCTIONS COULD POTENTIALLY DAMAGE YOUR MOUNT.

ULTIMATELY REFER TO SCOPE MFG SPECS BUT DO NOT EXCEED THE SPECS DISPLAYED HERE